

# TEBBEN SCISSORLIFT PONTOON TRAILER PARTS LIST & BREAKDOWN



**MODELS: PSL1820, PSL2123, & PSL2426**

**PART NO. 76-100**



**Tebben Enterprises - 10009 Highway 7 SE - Clara City, Minnesota 56222**

**Tel: (320)847-2200**

**[www.tebben.us](http://www.tebben.us)**

# PONTOON SCISSOR LIFT WINCH STAND ASSEMBLY

1. Attach winch stand using (2) 3/8" x 5 x 3.125 x 5 u-bolts to tongue as shown in photo.



2. Remove bolt that holds cable eyelet to winch stand leaving pulley attached, then unroll cable until 3 to 4 wraps are left on cable drum.
3. Attach cable eyelet back to winch stand and remove bolt holding pulley's on top frame. Put 1<sup>st</sup> pulley on cable with cable from winch stand on bottom side of pulley. Push pulley in space until able to insert bolt through pulley. Stop when half way through bracket.
4. Put 2<sup>nd</sup> pulley with cable on top of pulley, push bolt through and start nut on bolt.
5. Put 3<sup>rd</sup> pulley on cable with cable on bottom side of pulley. Push bolt through and start nut on bolt.
6. Tighten until touching bracket. Do not over tighten so pulley's can rotate freely.

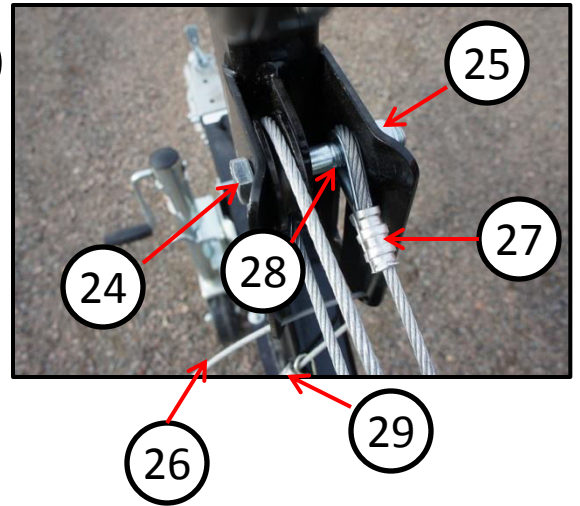
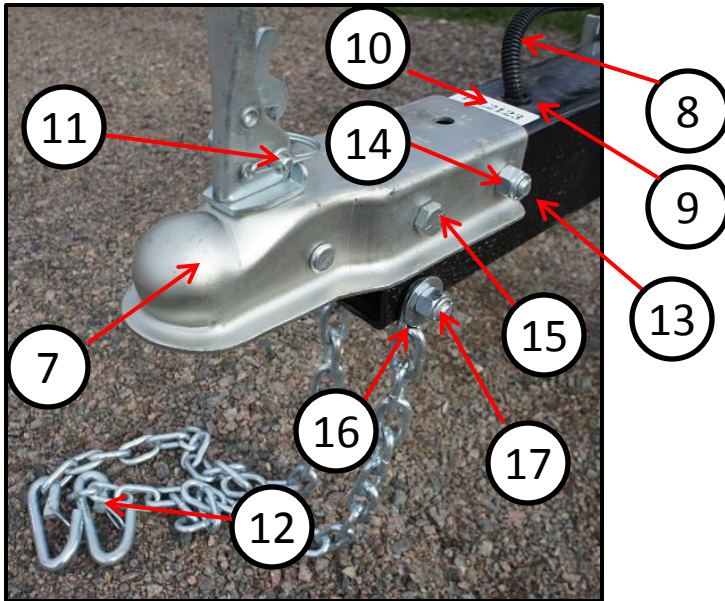
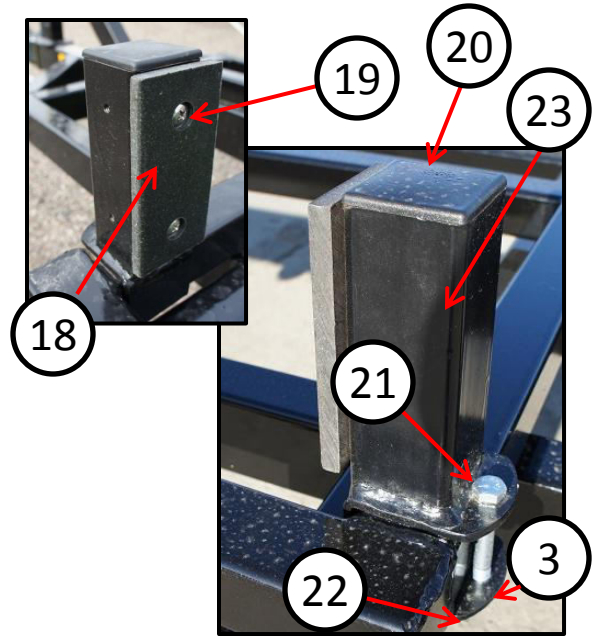
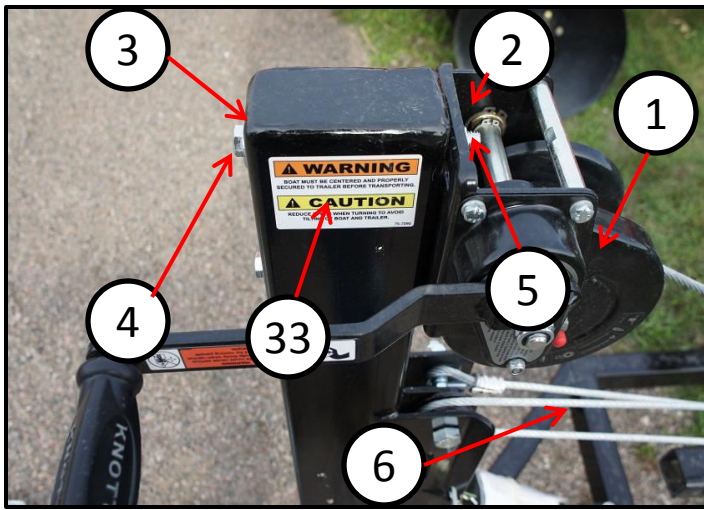

<b>REF.</b>	<b>PART NO.</b>	<b>DESCRIPTION</b>	<b>QTY PER</b>
1.	76-3002	1500 LB BRAKE WINCH	1
2.	61-927	3/8 LOCK WASHER	2
3.	19-5018	3/8 FLAT WASHER	6
4.	BT1C680	3/8-16X5 HEX BOLT ZC	2
5.	60-926	3/8-16 HEX NUT ZC	2
6.	76-3003	CABLE, 1/4", OAL 17'	1
7.	76-3000	COUPLER	1
8.	76-3026	3/8" LOOM, 3' OAL	1
9.	76-3008	NYLON GROMMET, 5/8"	1
10.	76-3009	MODEL NUMBER DECAL	1
11.	76-3010	SNAP PIN TAB LOCK, 5/16X1-3/4	1
12.	76-3011	SAFETY CHAINS	2

<b>REF.</b>	<b>PART NO.</b>	<b>DESCRIPTION</b>	<b>QTY PER</b>
13.	BT1C864	½-13X4 HEX CAP 5NC ZC	1
14.	BT51D8	½-13 HEX NUT, NYLOC ZC	4
15.	60-931	½-13X1 HEX CAP 5NC ZC	2
16.	61-613	½ FLAT WASHER ZC	2
17.	BT1C872	½-13X4-1/2 HEX CAP 5NC ZC	1
18.	76-355	UHMW BUMPER	2
19.	76-3012	¼-20X1/2 MACH TRUS PH STAI	4
20.	76-3013	2" SQ PLASTIC END CAP	2
21.	BT1C648	3/8-16X3 HEX CAP 5NC ZC	2
22.	BT51D6	3/8-16 HEX NUT NYLOC ZC	2
23.	76-1010L	FRONT BUMPER LH	1
	76-1010R	FRONT BUMPER RH	1
24.	76-3014	5/8-11X3-1/2 HEX CAP 5NC ZC	1
25.	60-901	5/8-11 HEX NUT, NYLOC ZC	1
26.	76-3015	¼ COAT CABLE ASSY	1
27.	76-3016	¼ WIRE ROPE SLEEVE	1
28.	76-3017	¼ THIMBLE	1
29.	76-3022	3/16 WIRE ROPE SLEEVE	1
30.	76-3027	WHEEL LUG NUTS (NOT SHOWN)	20
31.	TM76-00-42	5/8-11X3 HEX CAP 5NC ZC	1
32.	76-1009	PULLEY	3
33.	75-7090	DECAL	1

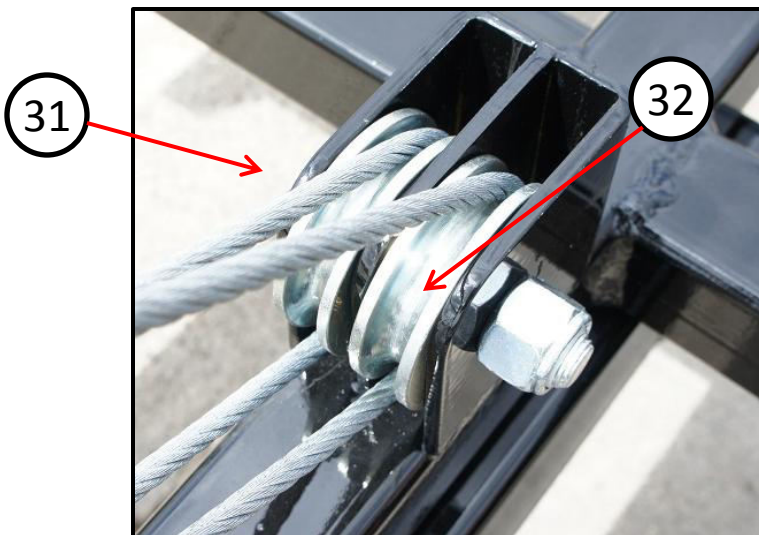

# SCISSOR LIFT PARTS BREAKDOWN & PARTS LIST

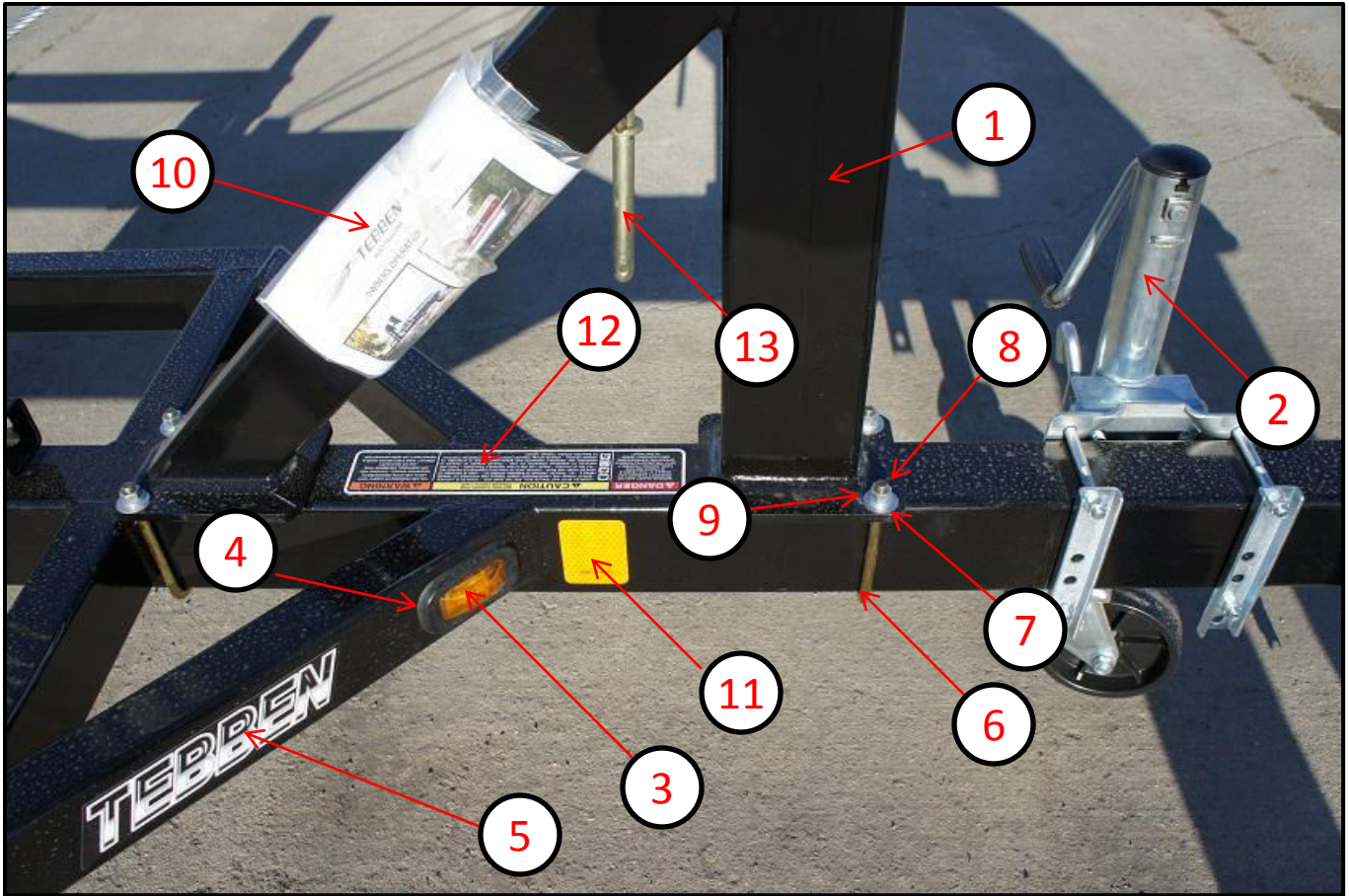

REF.	PART NO.	DESCRIPTION	QTY PER
1.	76-500	WINCH STAND	1
2.	76-3001	JACK	1
3.	76-3005	AMBER SIDE MARKER LIGHT	2
4.	76-3006	RUBBER GROMMET	2
5.	76-7045	TEBBEN DECAL	2
6.	75-3103	U-BOLT, 3/8X5X3.125X5	2
7.	19-5018	3/8 FLAT WASHER ZC	4
8.	60-926	3/8-16 HEX NUT ZC	4
9.	61-927	3/8 LOCK WASHER ZC	4
10.	7500-18	OPERATOR'S MANUAL	1
11.	76-3011	AMBER REFLECTOR	2
12.	76-7040	CAUTION/WARNING/DANGER DECAL	1
13.	76-3004	ZINC PLATED HITCH PIN, 5/8X4-1/4	1

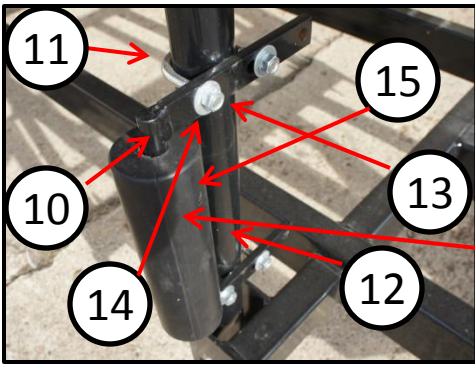
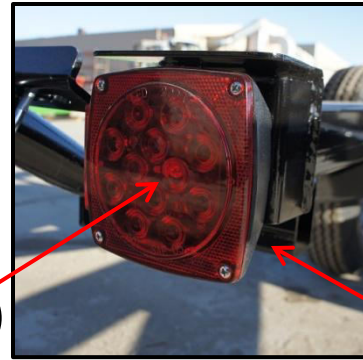
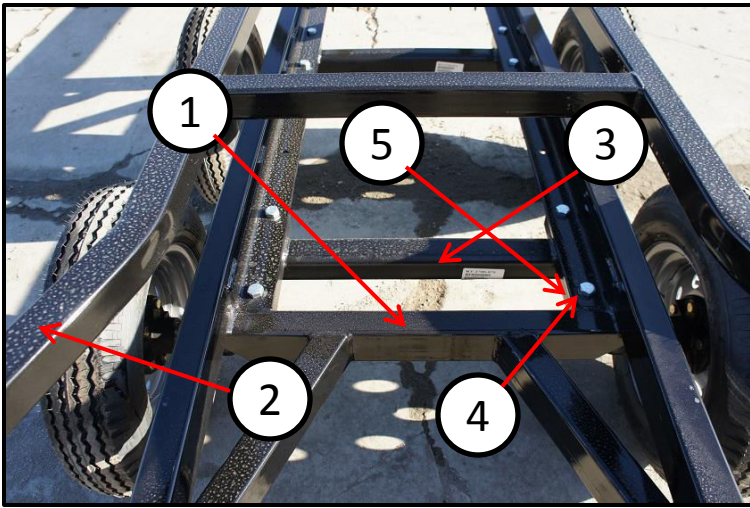

Clip not shown

ITEM # 16  
SIDE GUIDE ROLLER ASSEMBLY COMPLETE

REF.	PART NO.	DESCRIPTION	QTY PER
1.	75-380	20' BOTTOM FRAME	1
	75-387	22' BOTTOM FRAME	1
	75-373	24' BOTTOM FRAME	1
2.	75-378	20' TOP FRAME	1
	75-390	22' TOP FRAME	1
	75-374	24' TOP FRAME	1
3.	76-4000	2700 LB AXLE	2
4.	60-898	5/8-11X1-1/2 HEX CAP 5NC ZC	8
5.	60-901	5/8-11 HEX NUT, NYLOC ZC	8
6.	75-346	REAR BUMPER	2
7.	76-3018	5/8-11 NC GR. G FLANGE LOCK	2
8.	76-3019	TAIL LIGHT, CURBSIDE	1
	76-3020	TAIL LIGHT, ROADSIDE	1
9.	76-3021	FRAME CLIP	2
10.	76-3323	SIDE GUIDE ROLLER WELDMENT	8
11.	75-4001	U-BOLT, 3/8-16X2X2.63 RD	8
12.	76-307	ARM, PIVOT	VAR.

<b>REF.</b>	<b>PART NO.</b>	<b>DESCRIPTION</b>	<b>QTY</b>
13.	BT51D6	3/8-16 HEX NUT CENTERLOCK ZC	16
14.	19-5018	3/8 FLAT WASHER	16
15.	76-342	RUBBER GUIDE ROLLER	4
16.	76-331	SIDE GUIDE BRACKET ASSY	4

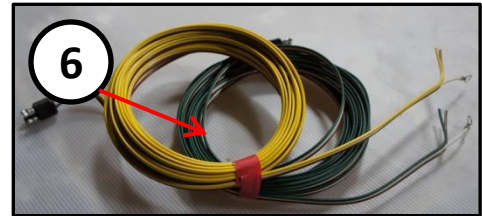
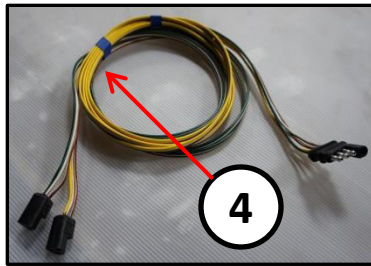
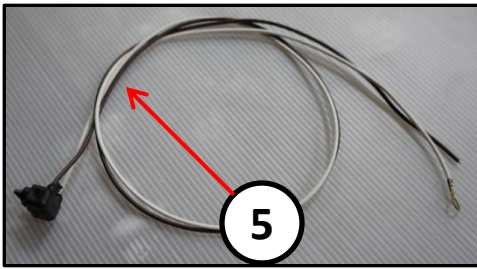
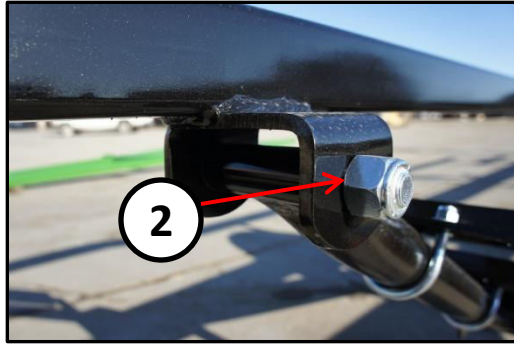
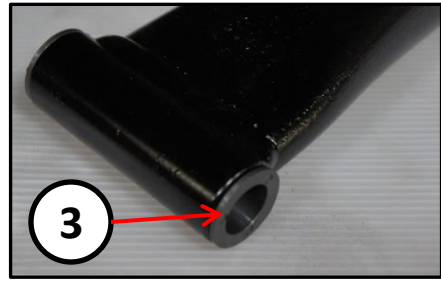
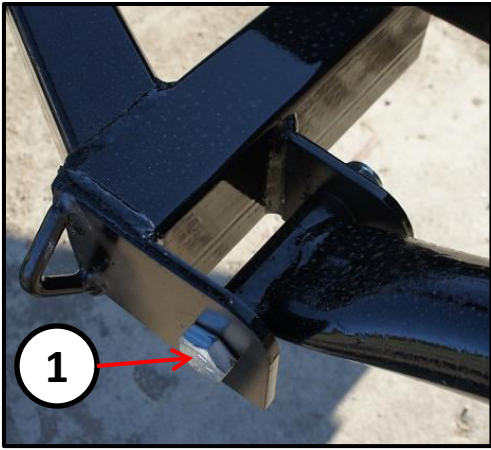

<b>REF.</b>	<b>PART NO.</b>	<b>DESCRIPTION</b>	<b>QTY PER</b>
1.	BT1C1072	5/8-11X4-1/2 HEX CAP 5NC ZC	VAR.
2.	60-901	5/8-11 HEX NUT, NYLOCK ZC	VAR.
3.	TZ75-00-53	NYLON BUSHING	VAR.
4.	76-3007	8' TONGUE HARNESS	1
5.	76-3023	2-WIRE PIGTAIL W/ 30" LEADS	2
6.	76-3024	20' FRAME HARNESS	1
	76-3025	25' FRAME HARNESS	1